

Main halyard - tie bowline at end, hook into pole end fitting - do not use the "D" shackle. This line will be highly loaded. Make sure it is securely cleated. If your main halyard is wire, you can switch positions with one of the jib/spinnaker halyards.

Note: In the lowered position, the top of the mast need to be supported at a high enough angle to be able to clear the cabin top. You will probably need extend your mast support by about 3 feet or so.

Upper and lower shrouds remain connected. Backstay should be loose, or can be disconnect on boats with chainplates aft of the mast.

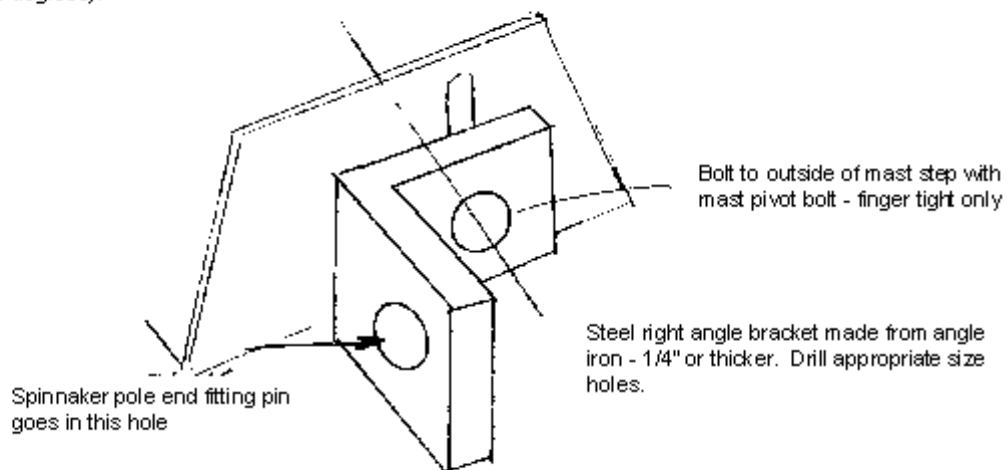
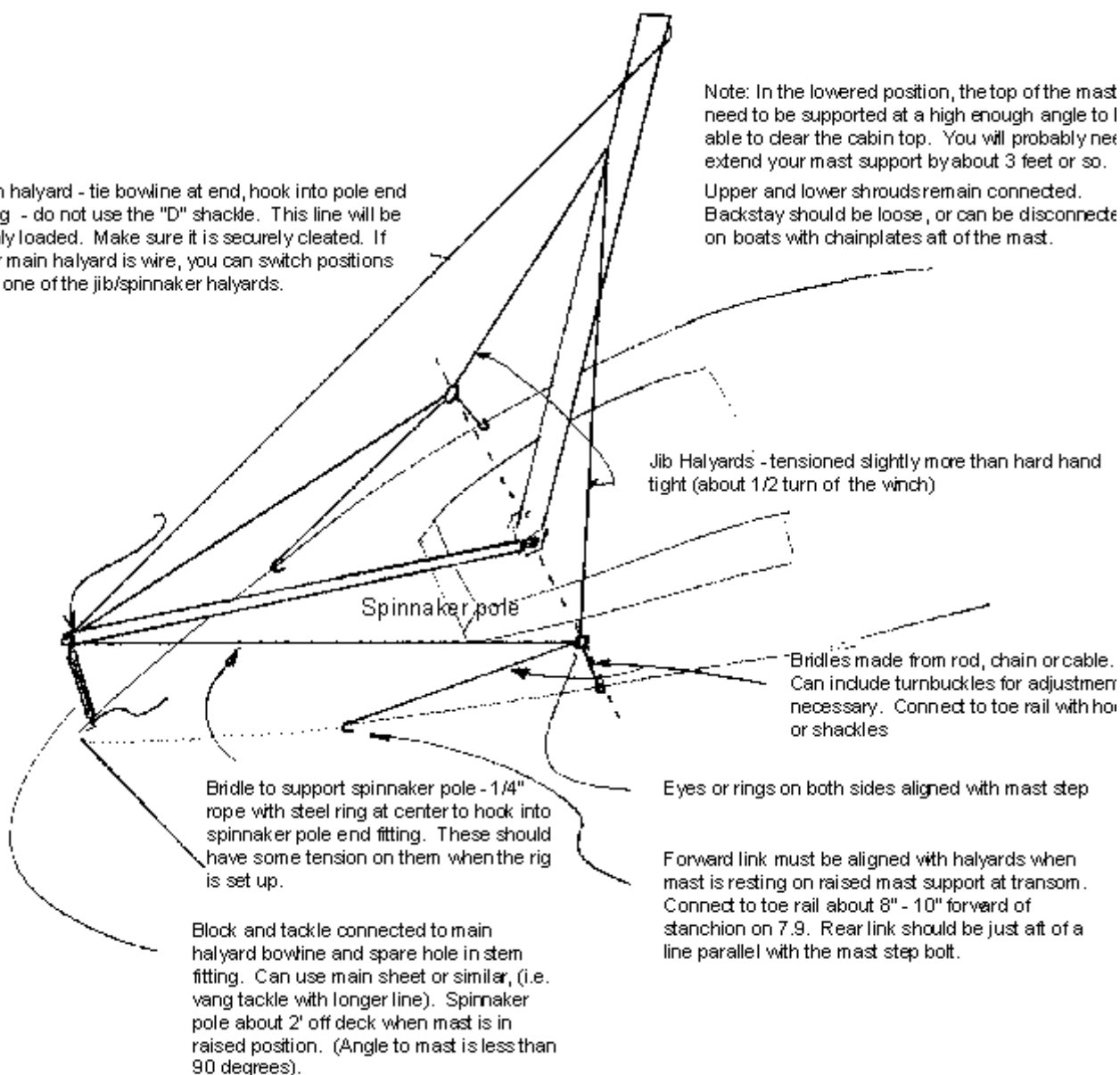

Disclaimer: The author, artist, and the S2 Class Association or any of its member fleets assume no responsibility for injury or damage caused due to the use of this or variants of this system. The user should be familiar with the process and understand the mechanics and risks before attempting to raise or lower a mast.

will
be
ad to

ad

t if
oks

|

e

|

1